

SANYO

INSTRUCTION MANUAL
8 mm Camcorder

VM-PS12

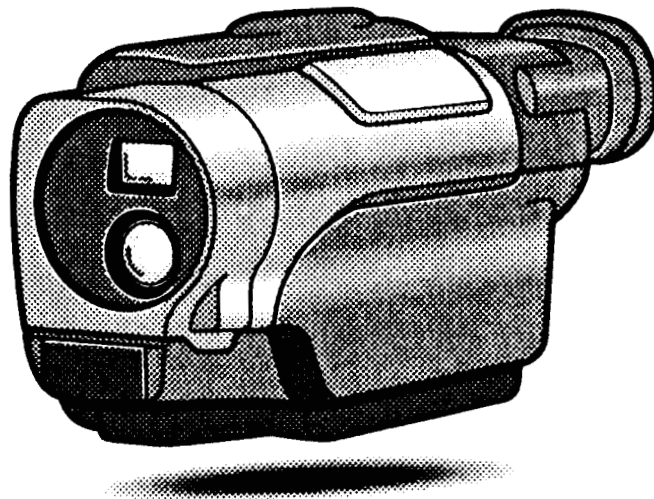

8 PAL

Contents

Precautions

Page

3

About the Camcorder

Page

5

Recording Steps

Page

7

Power Source

Page

9

Playback

Page

11

Maintenance

Page

13

Please read these instructions carefully before using the unit. Be sure to keep this manual for later reference.

The camcorder can be powered with a charged battery pack or by connecting the AC adaptor/charger.

Safety guards

■ England (BEAB) only

THIS PLUG IS NOT WATERPROOF-KEEP DRY

This cord is already fitted with a moulded plug incorporating a fuse, the value of which is indicated on the pin face of the plug. Should the fuse need to be replaced, an ASTA approved BS 1362 fuse must be used of the same rating, marked thus .

If the fuse cover is detachable, never use the plug with the cover omitted. If a replacement fuse cover is required ensure, it is of the same colour as that visible on the pin face of the plug (ie red or orange). Fuse covers are available from the Parts Department indicated in your User Instructions.

If the plug supplied is not suitable for your socket outlet, it should be cut off and destroyed. The end of the flexible cord should be suitably prepared and the correct plug fitted.

WARNING: A PLUG WITH BARED FLEXIBLE CORDS IS HAZARDOUS IF ENGAGED IN A LIVE SOCKET OUTLET.

IMPORTANT

The wires in this mains lead are coloured in accordance with the following code:



As these colours may not correspond with the coloured markings identifying the terminals in your plug, proceed as follows:

The wire which is coloured Blue must be connected to the terminal in the plug which is marked with the letter N or coloured Blue or Black. The wire which is coloured Brown must be connected to the terminal which is marked with the letter L or coloured Brown or Red.

WARNING: DO NOT CONNECT EITHER WIRE TO THE EARTH TERMINAL WHICH IS MARKED WITH THE LETTER E, BY THE EARTH SYMBOL \perp OR COLOURED GREEN OR GREEN/YELLOW.

■ Australia only

WARNING:

- Return to supplier for repairs.
- Should the power supply cord become damaged, it must be replaced by the special cord.

Precautions

- Do not put any furniture or other heavy object on the power cord, as that may cause a short circuit and start a fire.

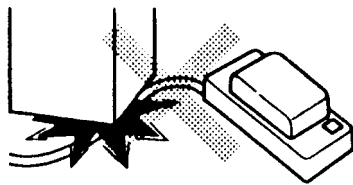

- Keep the power cord away from heat sources such as a heater, stove, etc.
- To unplug the power cord, pull from the plug, never the cord.
- Do not open the camcorder case. There are no user serviceable parts inside. Opening the case may damage the camcorder.

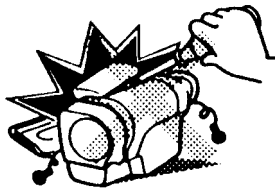

- When the cassette compartment is opened, make sure no foreign object falls inside the camcorder, as that may cause damage to the camcorder and/or start a fire when the camcorder is used.
- Keep the camcorder away from children, and make sure they do not put their hand in the cassette compartment.
- Do not use the camcorder outside during a storm or when there is lightning.

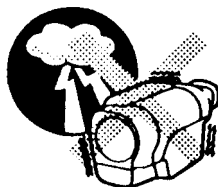

- **Do not use commercially available wet-type video head-cleaning cassettes.** They may damage the video heads in your unit. For the most suitable head-cleaning cassettes, please consult the dealer where the unit was purchased.

- Do not wrap the camcorder in a cloth, as the temperature inside will rise and damage the unit. If you notice anything unusual (smoke, strange noise or odour, etc.), stop using the unit and switch it off immediately. Remove the battery pack or disconnect the DC connecting cord, then consult the dealer where the unit was purchased, or contact an authorized service centre.

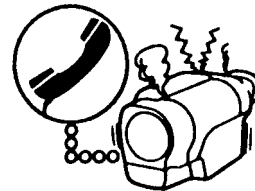

Precautions concerning magnetic fields

Do not leave/use the camcorder near magnets, or magnetic fields as they may damage the recordings on the tape.

Precautions during recording or playback

- Do not let direct sunlight hit the lens, as that may cause damage to the unit.

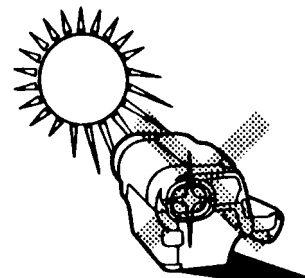

- Do not use the camcorder near transmitting antennas, as this might cause the unit to malfunction.
- When using the camcorder at the beach, do not let it get wet.
- Do not allow sand or dirt to enter the unit.

Do not store the unit in the following locations:

- where it will be subject to direct sunlight (e.g. on a car dashboard, etc.),
- near bright light sources, or where the humidity level is high,

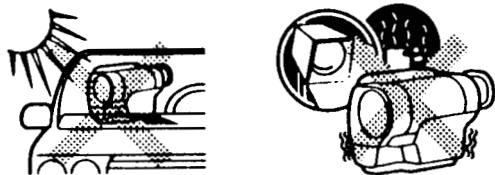

- in a closed car on warm or hot days, or close to a heat source (e.g. heater, stove, etc.),
- in the presence of excessive dirt or dust,
- where it will be subject to strong vibrations, or strong magnetic fields.

Condensation

Condensation is the moisture that forms on the outside of a glass when you fill it with cold water. The first sign of condensation is fogging of the camcorder lens and viewfinder.

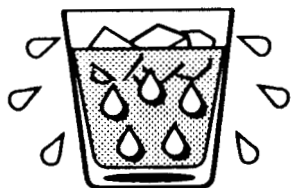

To stop the formation of condensation, wrap the camcorder in a cloth until the fogging on the lens and in the viewfinder disappears.

Do not use the camcorder before condensation has disappeared as that may cause damage to the video heads.

Conditions where condensation might appear

- If the camcorder is suddenly moved from a cold place to a warm, humid one, or vice versa.

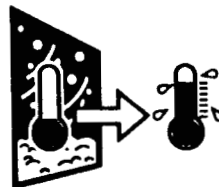

- If a heater has been turned on to quickly heat the room, or if the level of humidity is high.
- If taken from an air conditioned room, or car to a hot, humid place.

Condensation warning indicator

If condensation is detected inside the camcorder, the condensation warning indicator will flash in the LCD display. (See page 5.)

- As condensation may also appear inside the cassette casing, the cassette warning indicator might also flash when the cassette is loaded. Do not load a cassette in the camcorder if you suspect that condensation has formed inside the cassette.

If condensation has formed

Eject the cassette and wait for 1 – 2 hours for the condensation to dry.

The time required to completely eliminate condensation may vary.

WARNING:

UNAUTHORIZED RECORDING OR USE OF TELEVISION PROGRAMMING, BROADCASTS, VIDEO TAPE, FILM OR OTHER COPYRIGHTED MATERIAL MAY VIOLATE APPLICABLE COPYRIGHT LAWS. **SANYO** ASSUMES NO RESPONSIBILITY FOR UNAUTHORIZED DUPLICATION, USE OR OTHER ACTS WHICH INFRINGE UPON THE RIGHTS OF COPYRIGHT OWNERS.

About the Camcorder

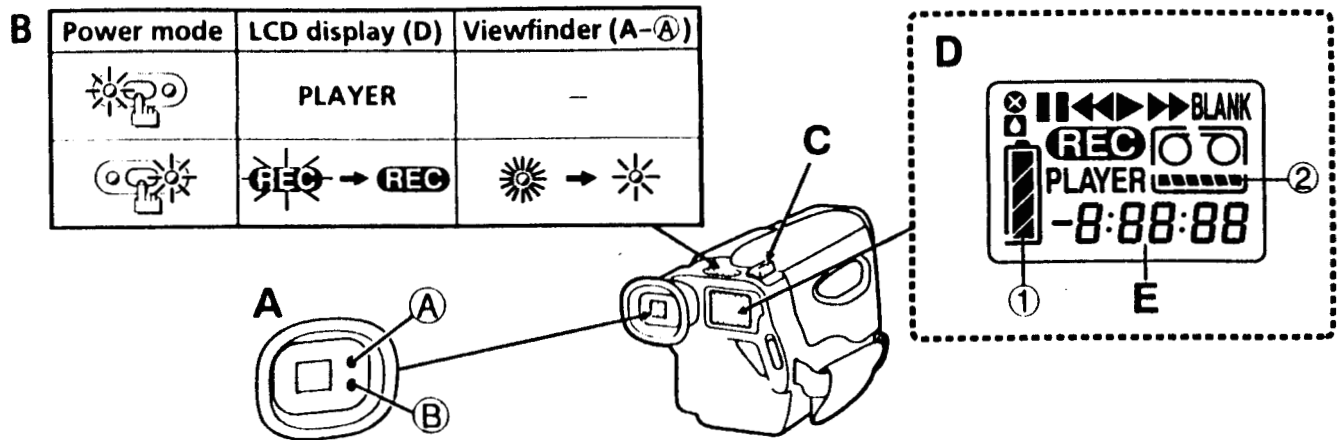

A. Viewfinder

It is not possible to view the tape playback on the optical viewfinder of this unit. For instructions on how to view a tape using a television monitor, please refer to pages 11 and 12.

B. Power mode button

When the power is turned on, the unit will automatically go into recording pause mode (if a tape is loaded). A different mode (**PLAYER** or **CAMERA**) is selected every time this button is pressed.

During recording, **REC** and the Recording indicator (Ⓐ) will turn on.

C. Zoom Lever (x3)

Move the zoom lever towards the **T** (telephoto) or **W** (wide-angle) as desired. The approximate focus ranges are shown below. However, the minimum focus distance varies according to the brightness of the subject, the actual distances may be slightly different.

- T:** Subject must be approximately 1.6 m or more from the front of the lens (Zoom in).
- W:** Subject must be approximately 0.7 m or more from the front of the lens (Zoom out).

D. LCD display

- ① Battery charge indicator (Battery is fully charged.)
- ② Tape remaining indicator
During recording and playback, the indicator does not appear for several seconds while the remaining tape is calculated.

Warning indicators (blinking)

When in **CAMERA** mode, the warning indicator (Ⓑ) is blinking.



: The battery power is running out and the power will soon turn off.



: The tape is within about 5 minutes from the end.



: The tape has reached the end.

- The erasure-prevention switch on the cassette is set to the red position (See page 8).
- No cassette is loaded.
- Condensation has formed inside the unit or the cassette.



: The video heads are dirty (See page 13).



: Condensation has formed inside the unit or the cassette.

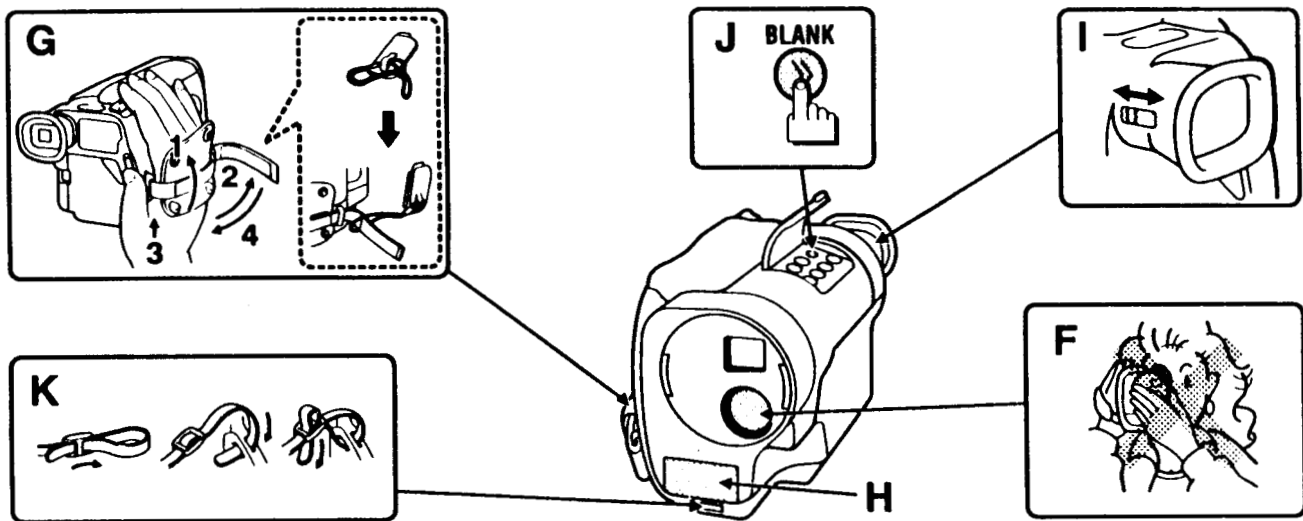

E. Tape counter

The tape counter will be reset under the following conditions:

- When the cassette compartment is closed after a cassette is inserted.
- When the power is restored to the unit after the battery pack or the DC connecting cord has been disconnected.

F. Camera lens

Be careful not to block the lens or to get it dirty, as it may show on your recordings.

Dirt and fingerprints can be removed with a soft dry cloth.

G. Grip belt

Use the grip belt to carry the camcorder.

Never hold it by the battery pack compartment cover or other than the grip belt.

H. Microphone (monaural)

I. Eyesight compensation lever

While looking into the viewfinder, move the lever back and forth to obtain the clearest possible image inside the viewfinder.

J. Blank search

The blank search function lets you easily find the end of the recorded portion on the tape (the beginning of the blank portion).

When in **CAMERA** mode, set to recording pause mode, and when in **PLAYER** mode, set to stop mode, then press the **BLANK** button.

Note

Before starting to record, it is recommended to confirm the stop position of the Blank search function. If previous recordings have been made with blanks in between the recordings, the blank search function may stop between two recordings if the blank is longer than 60 seconds.

K. Shoulder belt (sold separately)

Install the shoulder belt as illustrated.

Tripod screw mount

Located under the unit.

Recording Steps

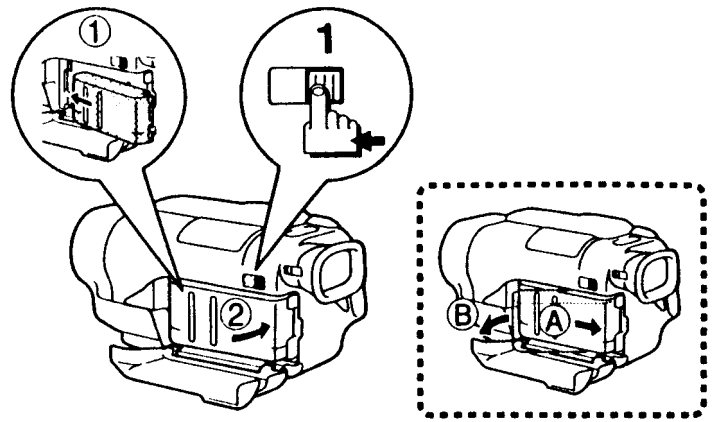
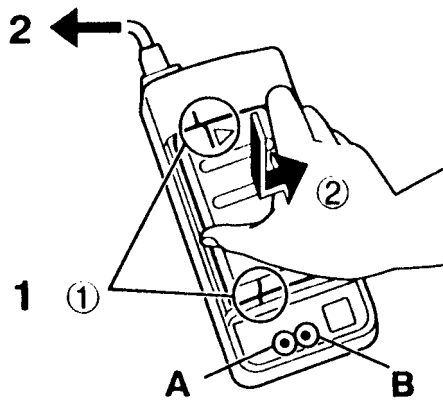

1 Charging the battery pack

The supplied battery pack has not been charged. Make sure to charge it before using it on the camcorder for the first time.

- 1 Align the marks on the battery pack with the ones on the AC adaptor/charger (①). When pressing it down, slide it in the direction of the arrow until it clicks into place (②).
- 2 Plug the AC adaptor/charger power cord into an AC outlet.
The **POWER** indicator (A) and the **CHARGE** indicator (B) light.
- 3 When it is fully charged, the **CHARGE** indicator will go off.

Remove the battery pack in the reverse order of installation.

Note

- When finished, make sure to unplug the AC adaptor/charger power cord from the AC outlet.
- If the **CHARGE** indicator flashes rapidly, remove the battery pack immediately, then try again making sure the battery pack is correctly installed. If the **CHARGE** indicator still flashes rapidly, it may indicate that the battery pack cannot be used. Please consult your dealer for assistance.

2 Installing the battery pack

- 1 Slide the **OPEN-BATT** button.
Carefully open the battery pack compartment cover fully.
- 2 Insert the top of the battery (①), then press down on the other end (②) to install it. Make sure it clicks into place.

To remove the battery pack, slide it toward the back of the camcorder (A), then lift it (B).

Note

- This camcorder can only be used with battery packs NP-55 and NP-65 (sold separately).

Do not use the AC adaptor/charger (VAR-S12) for any purpose other than charging the battery packs (NP-55 or NP-65), or supplying power to this camcorder.

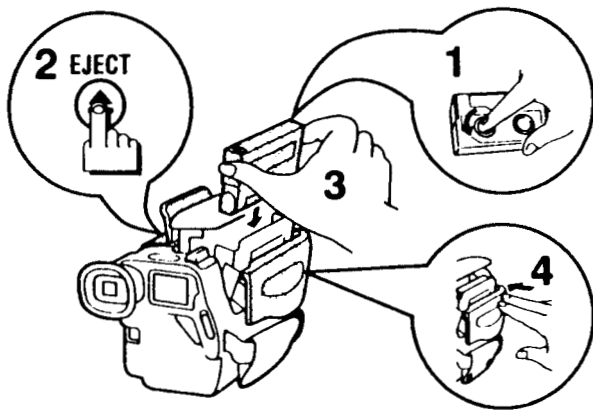

3 Loading a cassette

- 1** To eliminate loose tape inside the cassette, gently turn the left reel at the bottom of the cassette with a finger.
- 2** Press the **EJECT** button. The cassette holder will open.
- 3** Insert the cassette fully, with the door toward the bottom and the window facing out.
- 4** Gently press on the **PUSH** indication on the cassette holder until it clicks into place.
The tape counter is reset to 0:00:00.

To eject the cassette, press the EJECT button.

To prevent accidental recording on a tape with a previous recording you wish to keep, set the erasure-prevention switch to the red position (B).

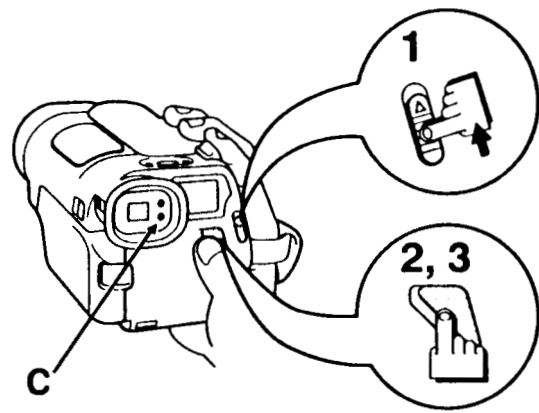

4 Recording

- 1** Push the **POWER** button.
- 2** Press the **REC** button to start recording.
- 3** To stop recording, press the **REC** button again.
When finished recording, turn the power off.

Note

- If a recording pause continues for more than 3 minutes, the power is cut to prevent the tape from being damaged.
- For best recording results, record a well lit subject, and as much as possible, keep the sun and other light sources behind you when recording.
- If the yellow indicator (C) flashes, it indicates that a warning indicator has lit on the LCD display. Please refer to page 5 for explanations of the warning indicators.

Power Source

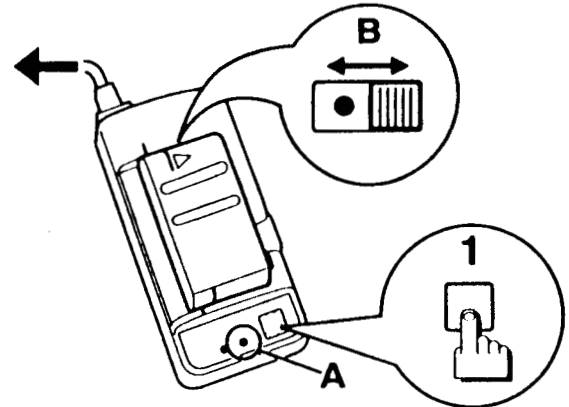
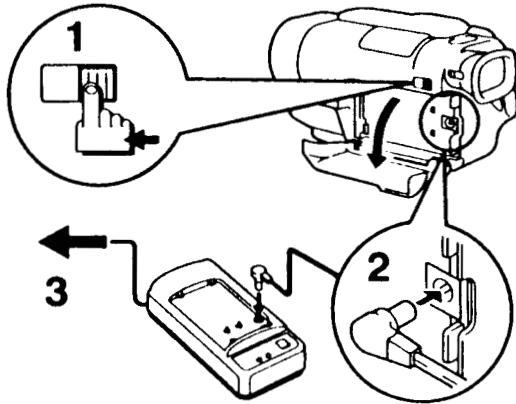

Using the DC connecting cord

- 1 Open the battery pack compartment cover.
- 2 Connect the DC connecting cord from the DC output terminal on the AC adaptor/charger to the DC input terminal on the camcorder.
- 3 Plug the AC adaptor/charger power cord into an AC outlet.

The supplied AC adaptor/charger can be used in any country where the standard voltage is between 100 V and 240 V AC. In countries where a differently shaped plug is used, a plug adaptor must be used. (See your Sanyo dealer for details.)

For this product use the supplied AC adaptor/charger (conforming to the EIA Japanese standard, with a unified polarity type plug $\diamond-\oplus-\diamond$). Use of another AC adaptor/charger may cause trouble.

Refreshing the battery pack

- 1 Install the battery pack on the AC adaptor/charger, then press the **REFRESH** button. The **CHARGE** indicator (A) will flash (slow cycle), and the remaining charge of the battery pack will be discharged.
- 2 The **CHARGE** indicator will stop flashing and the battery pack will be charged automatically.

Charge condition indicator switch (B)

Use this switch as a reminder of the charge state of the battery. Set the switch to the RED position when the battery is discharged.

Battery packs

■ Recharging

The battery pack should only be recharged just before it will be used, or one day before at the most.

If the battery pack is recharged and not used, it will slowly lose its charge.

When recording, make sure to completely exhaust the charge of the battery pack.

If the battery pack is recharged when the previous charge is not completely exhausted, it may reduce the ability of the battery to be charged fully.

Charging the battery pack is possible within a temperature range of 10°C to 30°C (50°F to 86°F).

■ Battery pack charging/operating time

The charging and operating times shown in the table below are approximate.

Model	NP-55	NP-65*
Operating time	80 min.	110 min.
Charging time	60 min.	80 min.
Refresh time	210 min.	285 min.

* Sold separately

■ In the following cases the operating time of the battery pack will be shorter than normal, even after a full charge:

- If the battery pack is used for the first time.
- If used in low temperature conditions.
- If it is stored in a fully charged or partially charged condition.
- If the charge is completely exhausted and it is stored for a long period (more than 3 months).
- If stored at temperatures above 40°C (104°F).

The battery will be restored to its original condition after it has been used until completely discharged and recharged, or after it has been recharged using the Refresh function of the AC adaptor/charger two or three times.

The following operations also require power, and will shorten the operating time.

It is recommended that you have on hand enough charged battery packs to last 2 or 3 times the expected recording time:

- Recording pause mode.
- Loading and unloading the cassette.

■ Storing

Do not store a battery pack where it could reach high temperatures.

If the camcorder is not used for a long period, remove the battery pack. Otherwise, the battery pack will slowly lose its charge.

WARNING:

- Do not short-circuit the battery pack terminals, and never try to disassemble or modify the battery pack.
- Do not throw it into a fire, as it may explode.
- Do not get wet.
- When not in use, the battery pack should be removed and stored in a cool, dry place.
- Do not drop or subject it to violent shock.
- If the terminals are dirty, use a soft cloth or tissue paper to clean them.



Note

**CONTAIN NICKEL-CADMIUM BATTERY.
MUST BE RECYCLED OR DISPOSED OF
PROPERLY.**

Playback

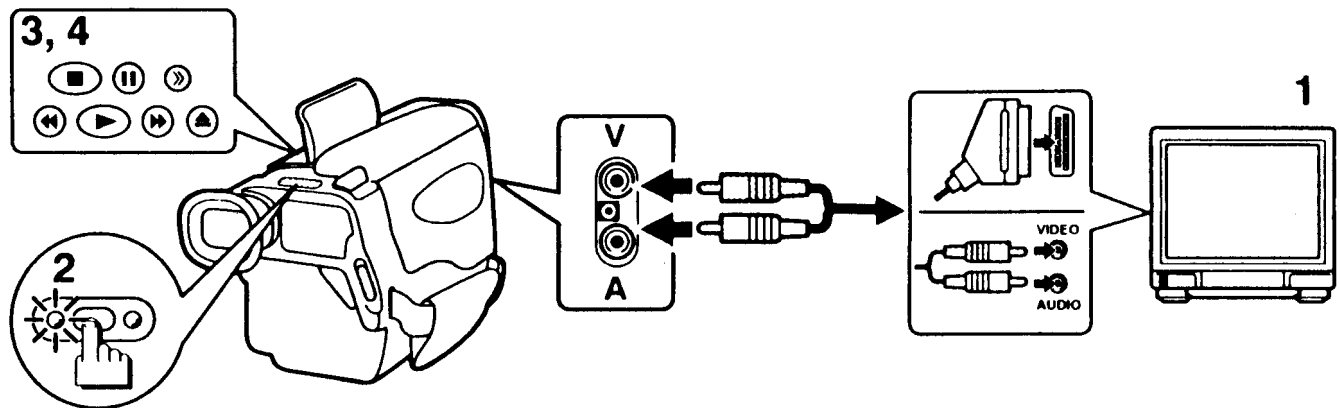

A. Connections to a TV equipped with a SCART terminal or AUDIO/VIDEO terminals

- 1 When connected, make sure to set the **TV/VCR** switch on the TV to "**VCR**".
- 2 Turn the power on and set to **PLAYER** mode.
- 3 Rewind the tape, if necessary, then start playback.
- 4 When finished, press the **STOP** button.

■ Picture search

During tape playback, press and hold the **REW** or **FF** button to view the picture at high speed.

Release the **REW** or **FF** button to resume normal playback.

■ Still picture

During playback, press the **STILL** button.

To resume normal playback press the **STILL** or **PLAY** button.

Note

- The sound is muted during picture search.
- During picture search operations, noise bars (horizontal white lines) or vibration will appear in the picture.
- If still picture playback continues for more than 3 minutes, the unit is switched to stop mode to prevent the tape from being damaged.
- This unit can playback tapes recorded in the LP (long play) mode.

Playback quality of the tapes recorded in the LP mode will be inferior to that of the tapes with the camcorder recorded in the SP mode.

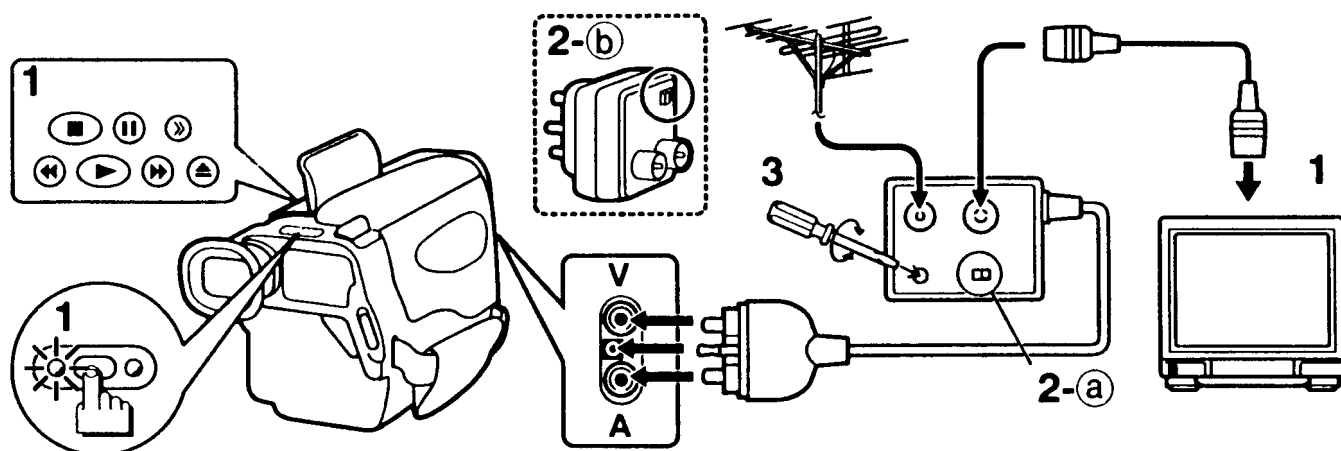

B. Connections to a TV not equipped with a SCART terminal or AUDIO/VIDEO terminals

1 Turn the TV on, and start playback on the camcorder.

2-a) England only

Set the I/G selector on the RF converter to the position corresponding to your TV standard.

3 Select an available channel between 30 and 39 on the TV, e.g. not used for broadcasting.

With a small screwdriver turn the RF channel screw on the RF converter until the picture and sound from the camcorder are played back clearly on the TV.

2-b) Australia only

Set the channel on the RF converter to the position corresponding to your TV setting. The picture and sound from the camcorder should be played back on the TV.

If no picture is visible, tune in your TV until the best picture and sound is obtained.

Tape copy

By connecting the camcorder to a VCR, you can copy the recorded tape in your camcorder to a tape that can be played back on your VCR.

For details, please refer to your VCR instruction manual.

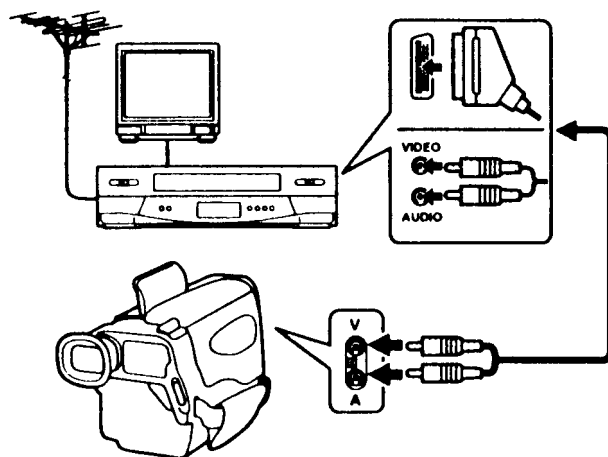

Note

Please refer to the accessories listing for the cable, converter and adaptor used for the connections.

Accessories not listed in the accessories listing must be bought separately.

Maintenance

Video head maintenance

When the camcorder has been used for a long time, the sound and picture playback quality on TV deteriorate (as illustrated). If this occurs, the video heads should be cleaned (dry-type).



If the playback quality is poor, even after cleaning the video heads, they might need to be replaced. For detailed information and assistance, please consult your dealer.

Note

Be very careful when using commercially available video head-cleaning products, as some might not be effective or they may damage the video heads.

Inspection at 1000-hour intervals

For continued trouble free operation and beautiful pictures, it is recommended that the unit be inspected (including cleaning, lubrication and replacement of worn parts as necessary), every 1000 hours of use (approximately). For detailed information and assistance, please consult your dealer.

Using the camcorder abroad

To watch playback on a TV, you will need to connect the camcorder to a TV that is equipped with audio/video terminals and conforms to the PAL television system.

Main countries using the PAL standard:

Australia, Austria, Belgium, Britain, China, Denmark, Germany, Holland, Hong Kong, Italy, Kuwait, New Zealand, Norway, Portugal, Singapore, Spain, Sweden, Switzerland, Thailand

Main countries using the SECAM standard:

Bulgaria, France, Hungary, Iran, Iraq, Luxembourg, Monaco, Poland, CIS

Main countries using the NTSC standard:

Canada, Japan, Korea, Mexico, the Philippines, Taiwan, U.S.A.

Specifications

■ Camcorder

- Television system** : PAL, CCIR
- Video recording system** : Rotating 2-head, helical-scan system
- Audio recording system** : Rotating head, FM system
- Cassette type** : 8 mm video cassette tape
- Tape speed** : Approx. 20.051 mm/sec. SP mode
- Maximum recording time** : 90 minutes (P5-90 cassette) SP mode
- Fast forward/Rewind time** : Approx. 6.5 minutes (P5-90 cassette)
- Image sensor** : CCD solid-state type (320,000 pixels)
- Viewfinder** : Optical viewfinder
- Lens** : 3x zoom F2.4~3.5 (f=3.6 to 10.8 mm)
- Focus** : Fixed focus
- White balance** : Fuzzy logic auto white balance
- Iris** : Fuzzy logic auto iris
- Minimum subject illumination** : 5 lux
- Subject illumination range** : 5 to 100,000 lux
- Recommended subject illumination** : 300 lux or more
- Power supply** : 6 V: battery pack
6.5 V: AC adaptor/charger
- Power consumption** : 4.5 W during camera recording
- Operating temperature range** : 0°C to 40°C (32°F to 104°F)
- Storage temperature range** : -20°C to 60°C (-4°F to 140°F)
- Dimensions (W x H x D)** : Approx. 93 x 105 x 182 mm
- Weight** : Approx. 630 g (excluding the battery pack and tape)
- Microphone** : Electret condenser type
- Video output terminal** : Video output 1 Vp-p, 75 ohms unbalanced, negative sync
- Audio output terminal** : Audio output -7 dBs, 2.2 kohms or less

■ AC adaptor/charger

- Rated output** : When connected to the camcorder: 6.5 V, 1.7 A
When recharging a battery pack: 10 V, 1.3 A
- Power requirement** : AC 100 V to 240 V, 50/60 Hz
- Power consumption** : 24 W
- Operating temperature range** : 0°C to 40°C (32°F to 104°F)
- Storage temperature range** : -20°C to 60°C (-4°F to 140°F)
- Dimensions (W x H x D)** : Approx. 72 x 39 x 156 mm
- Weight** : Approx. 300 g

The manufacturer reserves the right to modify produc. Desigins and specifications without notice and without incurring any obligation.

1AG6P1P0196--
ER12P/E, A (0994SY)

SANYO

SANYO Electric Co., Ltd.
Printed in Japan